

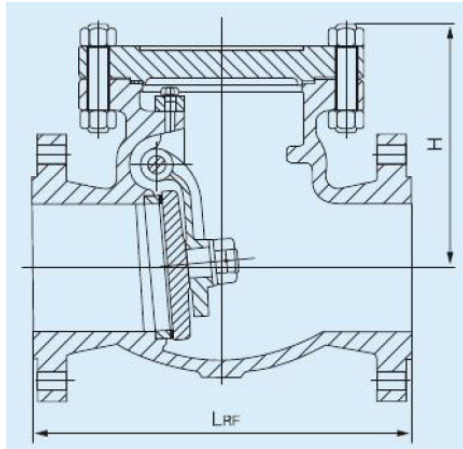

### 300LB API Flange Cast Steel Swing Type Check Valve



#### Parameters

| Pressure Class | Size |       | Main Dimensions |       |       |      | Weight(KG) |       | Cv    |
|----------------|------|-------|-----------------|-------|-------|------|------------|-------|-------|
|                | mm   | in.   | L(RF)           | L(BW) | L(RJ) | H    | RF         | BM    |       |
| 300            | 40   | 1-1/2 | 241             | 241   | 254   | 155  | 17         | 11    | —     |
|                | 50   | 2     | 267             | 267   | 283   | 161  | 20         | 12    | —     |
|                | 65   | 2-1/2 | 292             | 292   | 308   | 175  | 24         | 15    | —     |
|                | 80   | 3     | 318             | 318   | 333   | 203  | 45         | 29    | 285   |
|                | 100  | 4     | 356             | 356   | 371   | 228  | 65         | 41    | 515   |
|                | 150  | 6     | 445             | 445   | 460   | 279  | 115        | 75    | 1245  |
|                | 200  | 8     | 533             | 533   | 549   | 342  | 215        | 156   | 2285  |
|                | 250  | 10    | 622             | 622   | 638   | 381  | 310        | 220   | 3575  |
|                | 300  | 12    | 711             | 711   | 727   | 431  | 470        | 350   | 5345  |
|                | 350  | 14    | 838             | 838   | 854   | 482  | 550        | 386   | 6510  |
|                | 400  | 16    | 864             | 864   | 879   | 508  | 870        | 574   | 8620  |
|                | 450  | 18    | 978             | 978   | 994   | 584  | 1025       | 855   | 11155 |
|                | 500  | 20    | 1016            | 1016  | 1035  | 660  | 1500       | 1175  | 13935 |
|                | 600  | 24    | 1346            | 1346  | 1368  | 762  | 2500       | 2030  | 20420 |
|                | 650  | 26    | 1346            | 1346  | 1372  | 762  | 2800       | 2275  | 25000 |
|                | 700  | 28    | 1499            | 1499  | 1524  | 889  | 3000       | 2404  | 28750 |
| 750            | 30   | 1594  | 1594            | 1619  | 977   | 3400 | 2710       | 33910 |       |
| 800            | 32   | 1727  | 1727            | —     | 1016  | 3700 | 2897       | 42230 |       |
| 900            | 36   | 2083  | 2083            | —     | 1143  | 4300 | 3330       | 61570 |       |

**Wenzhou Kerui Valve Industry Co., LTD**

**Address:**

No.1 Tantou Village, Yongqiang High-tech Park, Longwan District, Wenzhou City, China

**Post Code:** 328024

**Tel:** +86-577-86928881 / +86-577-86990007

**Fax:** +86-577-86912312

**E-mail:** [sale@createvalve.com](mailto:sale@createvalve.com) / [offer@createvalve.com](mailto:offer@createvalve.com)